

THERMAL FLOW SWITCH FOR LIQUID APPLICATIONS

OSMIUM Series
Thermal Flow Switches



APPLICATION IDEAS

Cooling systems monitoring
Precision chemical dosing
Semiconductor processing control
Pharmaceutical manufacturing control
Brewing and distilling

Product Description

McMillan Flow Products introduces the OSMIUM Series, a highly robust thermal flow switch with a precision engineered flow body to create a reliable, cost-effective flow monitoring solution that requires minimal set-up and is easy to install.

Designed to achieve optimal flow conditions in a compact package, the OSMIUM thermal flow switch has options available to cover a wide range of flow rates and can be paired with an assortment of different process connections, providing flexibility for a variety of applications.

The OSMIUM's technology features microprocessor-based temperature compensation, ensuring reliable flow monitoring even in the presence of temperature fluctuation.

McMillan Flow Products offers a unique calibration service for this product to ensure exceptional performance and repeatability for each customer's specific application.

The OSMIUM thermal flow switch provides a simple and efficient solution for customers in need of reliable and cost-effective flow monitoring for their non-viscous water-based liquids.

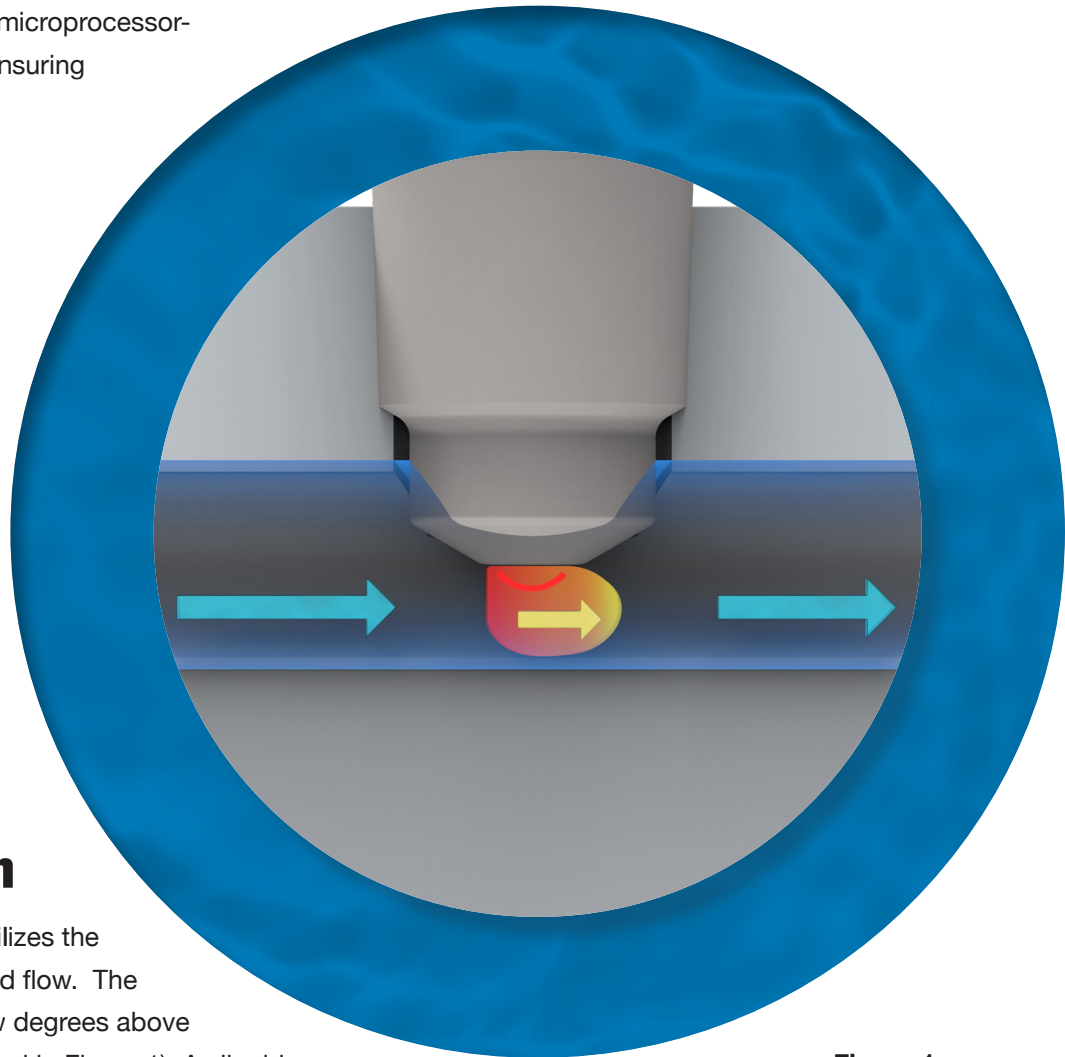

Figure 1
Illustration of sensor technology

Principle of Operation

The OSMIUM thermal flow switch utilizes the calorimetric principle to monitor liquid flow. The device's sensor tip is heated to a few degrees above the liquid temperature (as shown in red in Figure 1). As liquid flows across the tip (as shown in blue arrows), heat is carried away (as shown with the yellow arrow), cooling the sensor in the process. The amount of cooling is proportional to the liquid's velocity. The monitored flow is then compared to a programmed setpoint, which is field-adjustable by the user. A transistor switch is activated when the flow setpoint is reached.

The thermal flow switch is integrated into an engineered flow body that helps ensure optimal flow conditions are met. Design elements allow for a fully developed flow profile to be achieved, aiding the sensor in making the most accurate measurement possible. This engineered flow body makes installation quick and cost effective while ensuring reliable results for the customer.

Features and Options

FLOW BODY DESIGN AND FLOW RANGES

Flow bodies are designed to achieve optimal flow conditions in a compact package and are available in aluminum or stainless-steel construction. Flow ranges as low as 150 – 1000 mL/min to as high as 1.2 – 50.0 L/min are supported.



FLUID CONNECTIONS

Process connections are available in a wide variety of sizes and material construction. Range 1L | 10L | 20L units come stock with 3/8" FNPT ports, and Range 50L units come stock with 3/4" FNPT ports. Consult the Fitting Availability Chart located in the Ordering Information section on page 5 for more details.

MICROPROCESSOR-BASED TEMPERATURE COMPENSATION

The system achieves superior temperature compensation during the measuring cycle using a microcontroller. This ensures accurate correction of flow measurement even when liquid temperature changes occur.

SWITCH OUTPUT FUNCTION

This device utilizes a PNP open collector that is either normally open or normally closed. The normally open option enables a high-resistance state when flow is below the setpoint. The normally closed enables a high-resistance state when flow is above a setpoint.

ELECTRICAL CONNECTION

Units come standard with a 4-Pin Micro DC connection. Optional mating cables with various lengths are available.

CALIBRATION SERVICES

Our expert technicians can set up the device based on individual application parameters, including adjusting the flow range and setting the switch point to a desired rate. This service helps minimize installation and setup time, allowing for a more streamlined and efficient workflow. For optional custom calibration services, please contact the factory or an authorized representative for more information.

MOUNTING KIT

Optional steel mounting hardware is available. The mounting kit includes a fixed set screw that aligns with a socket feature on the device to insure optimum positioning.

DISPLAY

An array of 8 LEDs is used to visually monitor general flow rate. A blinking setpoint LED function can be adjusted along the array to indicate when the device should switch.



Specifications

	8721	8723
Medium	Water-Based Liquids Water Content \geq 90% Not Suitable for Oils or Fuels	
Liquid Temperature	-4 to 176 °F [-20 to 80 °C]	
Ambient Temperature	-4 to 140 °F [-20 to 60 °C]	
Max Pressure	Dependent on fittings Plastic Fittings = 200 psig [13 barg] Steel Fittings = 500 psig [34 barg]	
Signal Delay on Start-Up	Max 12 sec	
Switching Range	Velocity Dependent (See Flow Range Chart on page 5) 0.15 to 6.6 ft/sec	
Repeatability	\pm 2% Full Scale	
Response Time	5.6 sec Signal Cycle	
Switch Point Adjustment	Potentiometer Optical Indicator on LED Array Display (Blinking LED)	
Switch Point Threshold	\pm 12% Full Scale	
Flow Indication	Trend Indication 8-position LED Array Display	
Status Indicator	1 Dual Color (Green/Red) LED	
Power Supply	24 VDC \pm 10% at 150 mA max	
Power Consumption	Max 3.6 W	
Electrical Connection	Micro DC plug, 4-pin Male	
Electrical Protection	IP65 / NEMA 4X	
Switch Output	PNP open collector	
Switch Rating	400 mA max at 24 VDC Short Circuit Protected	
Wetted Materials	Aluminum 316L Stainless Steel	316L Stainless Steel
Fitting Materials	Dependent on Fittings (See Fitting Availability Chart on page 5)	
Electronics Housing Materials	304 Stainless Steel	

Ordering Information

Form part number as follows:

(Flow Body Construction) - (Power/Signal) - (Flow Range)

87

— — —

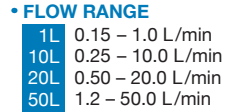
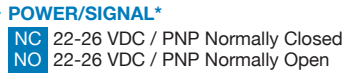
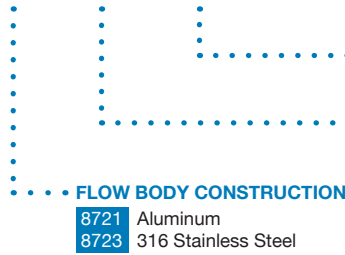

* NC option enables a high-resistance state when flow is **above** a setpoint.
NO option enables a high-resistance state when flow is **below** the setpoint.

EXAMPLES

8721-NO-1L would provide an aluminum-body thermal flow switch for liquids, would require 22-26 VDC power, have a PNP N/O signal, and would be calibrated to have a switchable range of 0.15 – 1.0 L/min.

8721-NC-50L would provide an aluminum-body thermal flow switch for liquids, would require 22-26 VDC power, have a PNP N/C signal, and would be calibrated to have a switchable range of 1.2 – 50.0 L/min.

OPTIONAL FITTINGS:

FITTING AVAILABILITY					
CODE	FITTING DESCRIPTION	RANGE CODE			
		1L	10L	20L	50L
9860-3-T6	PFA 3/8" tube fittings with 3/8" MNPT threads (pair)	✓	✓		
9860-3-T7	PFA 1/2" tube fittings with 3/8" MNPT threads (pair)	✓	✓	✓	
9863-3-T6	316L SS 3/8" tube fittings with 3/8" MNPT threads (pair)	✓	✓		
9863-3-T8	316L SS 5/8" tube fittings with 3/8" MNPT threads (pair)		✓	✓	
9863-6-T8	316L SS 5/8" tube fittings with 3/4" MNPT threads (pair)				✓
9863-6-T9	316L SS 3/4" tube fittings with 3/4" MNPT threads (pair)				✓
9863-6-T10	316L SS 1" tube fittings with 3/4" MNPT threads (pair)				✓
9864-3-T6	Acetal 3/8" tube fittings with 3/8" MNPT threads (pair)	✓	✓		
9864-3-T7	Acetal 1/2" tube fittings with 3/8" MNPT threads (pair)	✓	✓	✓	
9864-3-T8	Acetal 5/8" tube fittings with 3/8" MNPT threads (pair)		✓	✓	
9864-6-T9	Acetal 3/4" tube fittings with 3/4" MNPT threads (pair)				✓
9866-3-T6	PVDF 3/8" tube fittings with 3/8" MNPT threads (pair)	✓	✓		
9866-3-T7	PVDF 1/2" tube fittings with 3/8" MNPT threads (pair)	✓	✓	✓	

Dimensions

Basic unit configurations are shown. Contact factory or an authorized representative for dimensions of units not shown. All dimensions shown in inches [mm] unless otherwise noted.

MODEL 8721 / 8723 (RANGE 1L | 10L | 20L):

FITTING CODE	OVERALL LENGTH
9863-3-T6	7.3 [184.7]
9863-3-T7	7.6 [191.8]
9863-3-T8	7.6 [193.3]
9860-3-T6	8.1 [204.5]
9860-3-T7	8.3 [210.1]
9864-3-T6	7.6 [193.3]
9864-3-T7	8.0 [201.9]
9864-3-T8	8.2 [208.0]
9866-3-T6	7.7 [195.3]
9866-3-T7	8.0 [203.0]

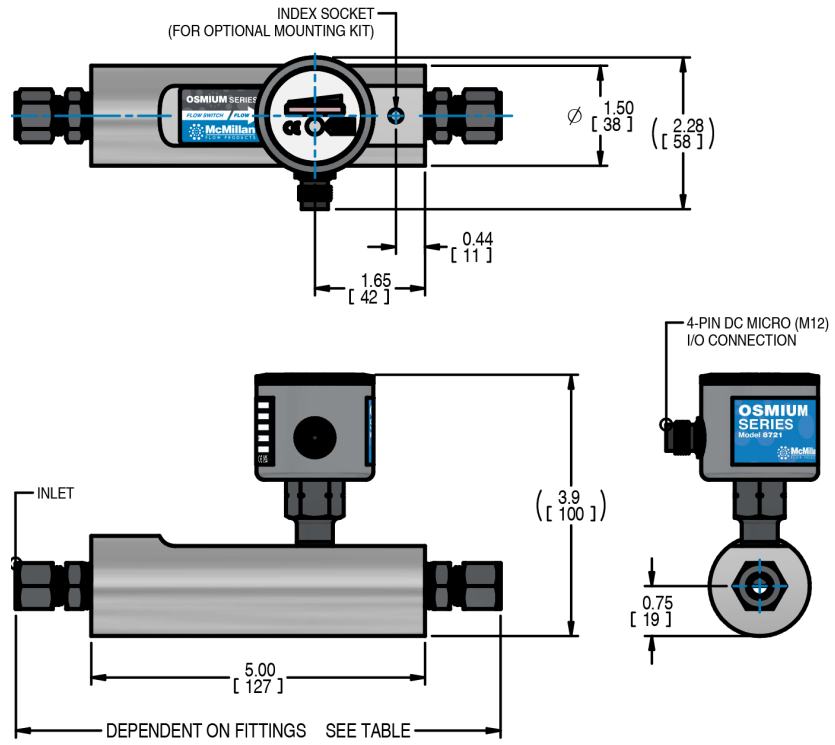

MODEL 8721 / 8723 (RANGE 50L):

FITTING CODE	OVERALL LENGTH
9863-6-T8	9.3 [236.5]
9863-6-T9	9.3 [236.5]
9863-6-T10	9.9 [250.7]
9864-6-T9	9.3 [235.5]

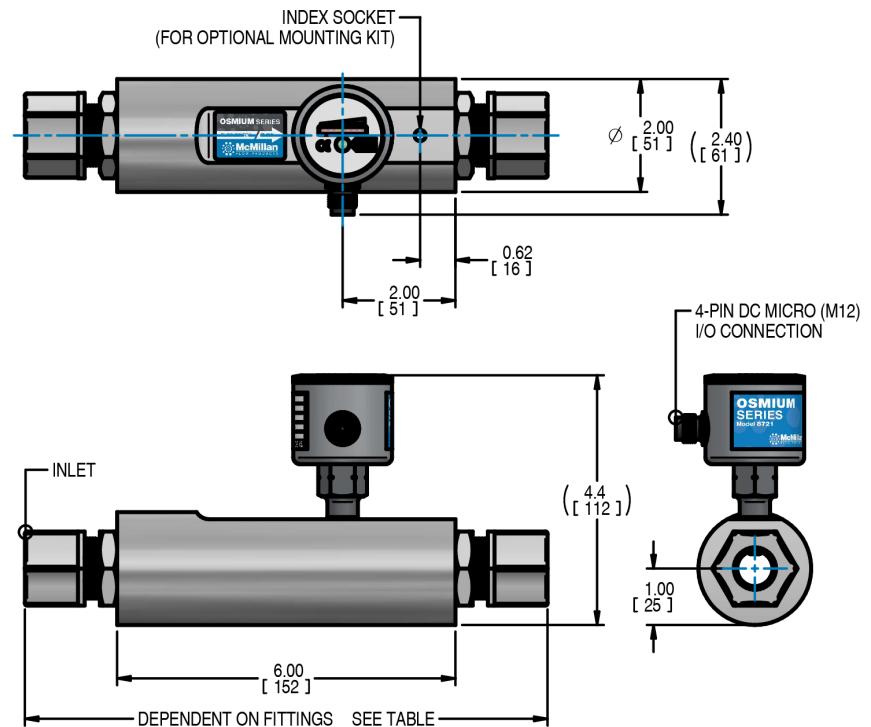

Dimensions

Basic unit configurations are shown. Contact factory or an authorized representative for dimensions of units not shown. All dimensions shown in inches [mm] unless otherwise noted.

OPTIONAL MOUNTING KIT (RANGE 1L | 10L | 20L):

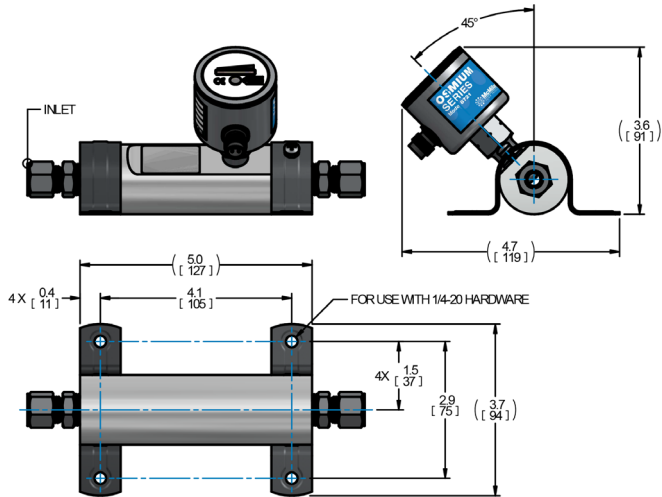

OPTIONAL MOUNTING KIT (RANGE 50L):

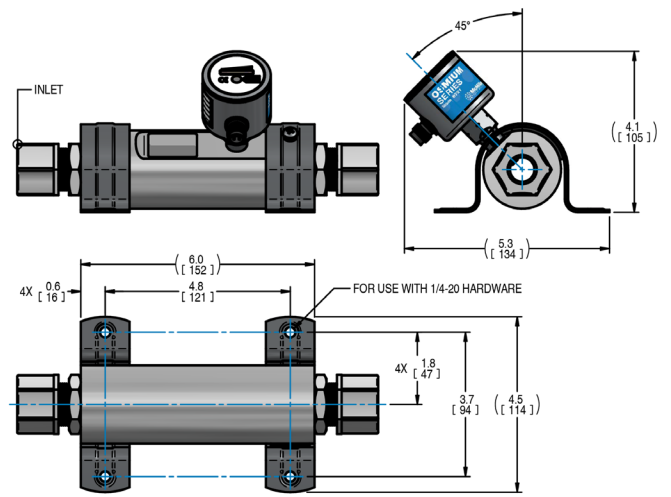

Options & Accessories

CODE	DESCRIPTION
9971-4-2M	Cable with M12 female connector, 4 conductor, 6.6 ft [2m]
9971-4-3M	Cable with M12 female connector, 4 conductor, 9.8 ft [3m]
8720-MK1	Mounting Kit for Range 1L 10L 20L
8720-MK2	Mounting Kit for Range 50L



McMillan Flow Products
P.O. Box 1340
Georgetown, Texas 78627
Toll-Free: (800) 861-0231 (U.S.A. only)
Direct: +1 (512) 863-0231
Email: sales@mcmflow.com
Website: www.mcmflow.com